

## PUMP PERFORMANCE CURVES

**PM45 40:1 RATIO** Flow Rate 22 lb/min (10 kg/min)  
Test Fluid: NLGI-1 at 70 °F (21°C)

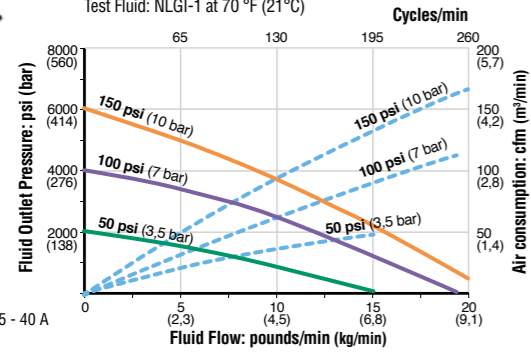

**PM60 80:1 RATIO** Flow Rate 13 lb/min (6 kg/min)  
Test Fluid: NLGI-1 at 70 °F (21°C)

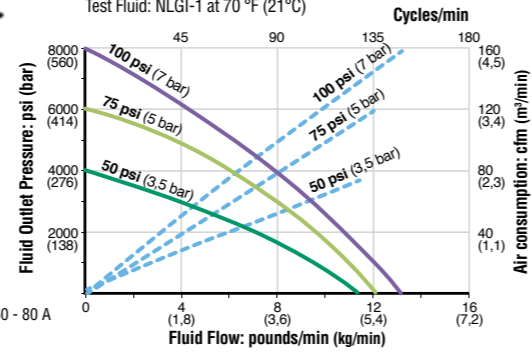

**PM45 70:1 RATIO** Flow Rate 12 lb/min (5.4 kg/min)  
Test Fluid: NLGI-1 at 70 °F (21°C)

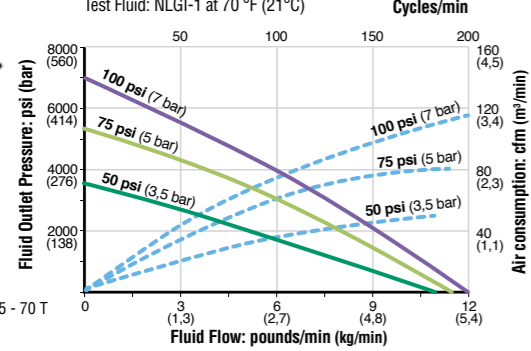

**PM60 12:1 RATIO** Flow Rate 85 lb/min (39 kg/min)  
Test Fluid: NLGI-1 at 70 °F (21°C)

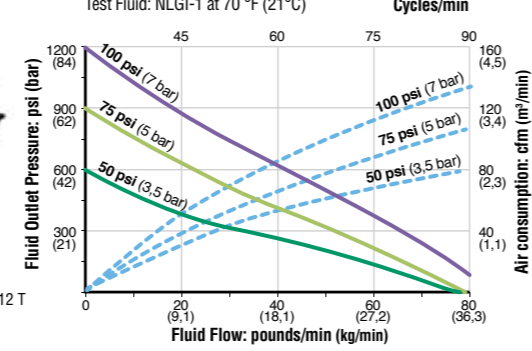

**PM45 25:1 RATIO** Flow Rate 30 lb/min (13.6 kg/min)  
Test Fluid: Gear Oil 140 at 70 °F (21°C)

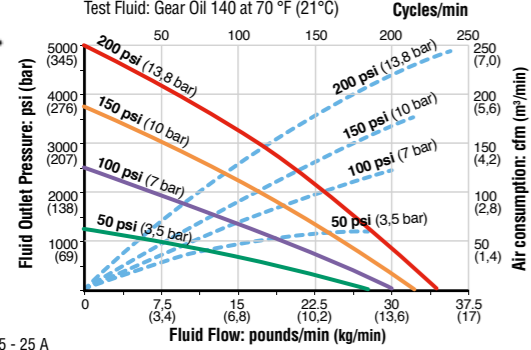

## GREASE PUMPS SELECTION

SIMULTANEOUS DISPENSING OUTLETS	TOTAL PUMP DISTANCE TO OUTLETS*	CONTAINER TYPE		
		180 kg / 400 lb (A)	50 kg / 120 lb (B)	Bulk Tote (T)
Over 3	Over 50 m / 150 ft	PM 45 - 40 A	PM 45 - 40 B	PM 45 - 70 T
Up to 3	Over 50 m / 150 ft	PM 45 - 40 A	PM 45 - 40 B	PM 45 - 70 T
Over 3	Over 50 m / 150 ft	PM 45 - 70 A	PM 45 - 70 B	PM 45 - 70 T

\* The hose length of the dispensing reels must be included in the total distance.  
\* The mentioned lengths refer to rigid pipelines made of at least 25 mm (1") outside diameter and 3 mm (0,125") thickness steel tubing with hydraulic type fittings.

## GREASE PUMP MOUNTING - DRUM SYSTEMS & BULK TOTES

### Cover-Mount with Follower Plate

- Economical.
- Follower sticks to the surface of the grease and goes down following the pump tube as the grease decrease.
- For viscous grease (NLGI-1).
- Suitable for drums:  
A - 180 kg (400 lb)  
B - 50 kg (120 lb)

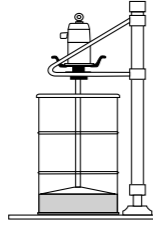

### Inductor Plate-Mount with Hoist

- Air operated hoist raises and lowers the pump and inductor assembly for easy drum changeover.
- Inductor is set at suction part of pump, sticks to grease surface and goes down according to grease decrease.
- Wiper inductor reduces waste.
- For viscous materials (NLGI-2).
- Improves pump performance.

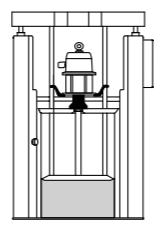

### Ram Hoist-Mount

- Air operated double-post hoist with inductor plate raises and lowers the pump assembly.
- Force feed high-volume pumps.
- Extreme viscous materials (NLGI-3).
- Wiper inductor reduces waste.
- Clean and easy drum changeover.

### Vertical-Mount

- Stubby grease pump for vertical mounting.
- Use the male portion of a 3" camlock connection for easy installation and tank (grease hopper) changeover.

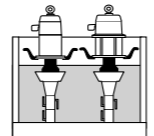

### Horizontal-Mount

- Stub grease pump for horizontal mounting and space constraints.
- Use the male portion of a 3" camlock connection for easy installation and tank (grease hopper) changeover.

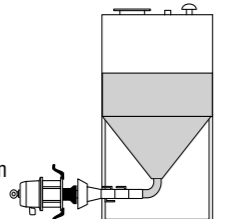

### Inclined-Mount

- Long tube grease pump for inclined mounting.
- Use the male portion of a 3" camlock connection as an accessory for easy installation and tank (grease hopper) changeover.

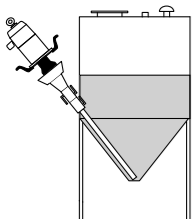

PUMP MASTER **45&60**  
LUBRICATION PUMPS

HIGH PERFORMANCE VOLUME DISPENSING PUMPS FOR GREASE

**GREASE**

INDUSTRIAL PLANTS • OFF-ROAD EQUIPMENT • MINING & CONSTRUCTION • LARGE FLEETS SERVICE • MARINE

Pneumatically driven industrial pumps: for hard to pump viscous lubricants or long delivery lines.



SAMOA INDUSTRIAL, S.A.  
Pol. Ind. Porceyo, I-14 • Camino del Fontán, 831 • E-33392 Gijón (Asturias) SPAIN  
Tel.: +34 985 381 488 - Fax: +34 985 147 213 • export@samoaindustrial.com • www.samoaindustrial.com

# INDUSTRIAL LUBRICATION PISTON PUMPS: THE HEART OF A LUBRICATING SYSTEM

SAMOA piston pumps have been specifically designed to pump today's high viscosity greases and viscous lubricants at high flow rates and to lead the competition in technology and innovation. SAMOA manufactures a full range of Heavy-Duty, high efficiency, air powered, double acting, positive displacement piston pumps. Our wide range of pumps provides the necessary confidence to offer solutions for fast moving large volumes of grease.

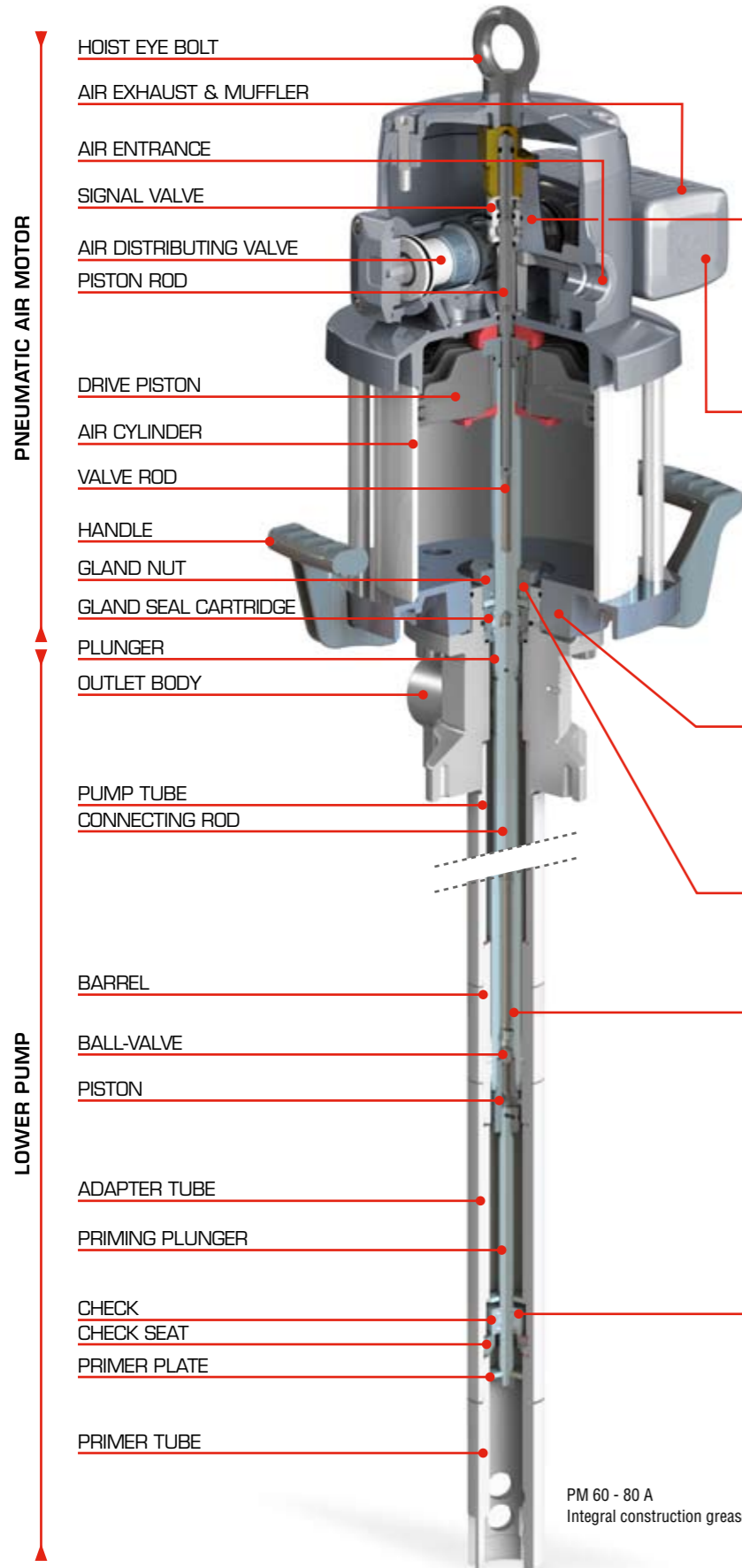

**Pneumatic Air Motors:** our compact air motors are actuated by a mechanically linked signal valve mounted on a trip rod (piston rod) which senses when the drive piston has reached an end of stroke and sends an instantaneous air signal to the air distributing valve maintaining it stable in a fixed position and supplying air to one piston side while evacuating the air of the other side, thus creating the fast reciprocating action of the air motor. This simple concept eliminates the possibility of stalling. This time-tested pneumatic air motor only has three moving parts and no springs, which could fail or consume energy and runs without external lubrication.

**Air exhaust:** Aluminium air motor provides good heat transfer and incorporates high-thermal efficiency, large diameter, air exhaust manifolds together with a free-flow exhaust way at the distributing valve that literally opens the exhaust side of the power chamber to the atmosphere, eliminating pump performance variability caused by changing environmental conditions and icing-up. The supplied muffler element reduces the noise to meet or exceed OSHA requirements in all recommended operational air pressures. The muffler can also be removed to connect the exhaust port, through a hose, directly to a remote location for a quieter operation.

**Modular design:** The robust, modular pump design permits multiple-combination assemblies of air-motor and lower-pump end. This versatile pump construction for easy service and maintenance provides a comprehensive selection-range of operating output pressures and flow-rates to accommodate any amount of dispensed lubricant.

**Pump top gland seal:** our anti-corrosive, hardened, plunger and the cartridge packing arrangements are designed for low-friction, to minimize the wear and maximize tightness and seals life.

**High quality materials:** Aluminium die-cast pneumatic air motor with hard anodized aluminium cylinder; light weight drive piston and plunger with rubber-PTFE or polyurethane seals; cast outlet body, thick-wall polished tube, high tensile steel on rod; barrel, piston and prime valve made of special hardened, precision fitted, ground steel for perfect seal and long life of grease pumps.

**Pump inlet valve:** Together with the Double-Valve style pump tube used for positive priming and pumping of heavy gear oils and lubricants up to NLGI 1 (25:1), SAMOA offers a Chop-Check priming valve that assists the entry of heavy and sticky greases up to NLGI 3 into the pump and improves pumping efficiency.

PM 60 - 80 A  
Integral construction grease pump

## PUMP MASTER 45&60 LUBRICATION PUMPS

# INDUSTRIAL GREASE PUMPS

### PNEUMATICALLY DRIVEN GREASE PUMPS

SAMOA PM45 and PM60 air operated lubricant pump range consist of the following models. Based on the use of two air motors combined with seven different pump piston sizes, the configuration options allow each pump to be fine-tuned providing the perfect performance to match any application and give years of trouble free, reliable operation. The pumps cover a wide range of applications whether for pumping, metering, lubricating, filling or transferring in industrial plants, off-road equipment service, feeding lubricant to a mine or a construction process, when servicing large fleets and in marine applications.



	PUMPMASTER 45	PUMPMASTER 60
<b>Air motor effective diameter</b>	4 1/2" - 115 mm	6" - 150 mm
<b>Stroke</b>	4" - 100 mm	4" - 100 mm
<b>Air pressure range</b>	1,5-7 bar / 20 - 100 psi - (1,5 - 14 bar / 20 - 200 psi on 25:1 & 40:1)	
<b>Air inlet port</b>	1/2" BSPP (F) on "M" pumps - 1/2" NPT (F)	
<b>Air exhaust</b>	Exhaust Muffler included (3/4" (F) threaded port for remote exhaust)	
<b>Noise level @ 7bar - 100 psi</b>	80 dB (A)	
<b>Air Motor &amp; Pump Assembly</b>	Integral construction (for lubricants and non corrosive fluids)	
<b>Wetted Materials</b>	Cast iron, steel, copper, NBR, PTFE (Polyurethane on 25:1 & 12:1)	
<b>Fluid outlet port:</b> Grease - High Pressure 12:1 Grease Transfer	1/2" BSPP (F) on "M" pumps - 1/2" NPT (F) 1" BSPP (F) on "M" pumps - 1" NPT (F)	
<b>Fluid inlet type:</b> 40:1, 70:1 & 80:1 Grease High Pressure 12:1 Grease Transfer 25:1 Lubricant Pump	Immersed - Dynamic primer plate and Chop-check valve. Typically used with follower assembly Immersed - Dynamic primer piston for positive priming and Chop-check valve Immersed - Ball-check valve	

Model	Code	Air Motor Size (Ø)	Pump Ratio	Container type	Dimensions X-Y-Z	Max. Air Pressure	Max. Fluid Pressure	Displacement Per cycle	Standard* Flow rate	Maximum* Flow Rate	Weight
PM 45 - 25 A ■	531 211	4 1/2"	25:1	400 lb (A)	17,6-33,6-2 (in)	200 psi	5.000 psi	4,27 cu-in	13,5 lb/m	30 lb/m	50 lb
PM 45 - 40 A	531 411	4 1/2"	40:1	400 lb (A)	17,6-33,6-2 (in)	200 psi	8.000 psi	3,05 cu-in	7,5 lb/m	22 lb/m	50 lb
PM 45 - 40 B	531 421	4 1/2"	40:1	120 lb (B)	17,6-25,6-2 (in)	200 psi	8.000 psi	3,05 cu-in	7,5 lb/m	22 lb/m	40 lb
PM 45 - 70 A	531 711	4 1/2"	70:1	400 lb (A)	17,6-33,6-2 (in)	100 psi	7.000 psi	1,77 cu-in	4,5 lb/m	12 lb/m	50 lb
PM 45 - 70 B	531 721	4 1/2"	70:1	120 lb (B)	17,6-25,6-2 (in)	100 psi	7.000 psi	1,77 cu-in	4,5 lb/m	12 lb/m	40 lb
PM 45 - 70 T ★	531 731	4 1/2"	70:1	Bulk tote (T)	17,6-16,1-2 (in)	100 psi	7.000 psi	1,77 cu-in	4,5 lb/m	12 lb/m	40 lb
PM 60 - 80 A	532 811	6"	80:1	400 lb (A)	18,1-33,6-2 (in)	100 psi	8.000 psi	3,05 cu-in	6,0 lb/m	13 lb/m	53 lb
PM 60 - 80 B	532 821	6"	80:1	120 lb (B)	18,1-25,6-2 (in)	100 psi	8.000 psi	3,05 cu-in	6,0 lb/m	13 lb/m	43 lb
PM 60 - 12 T ▲ ★	532 131	6"	12:1	Bulk tote (T)	18,1-7,9-2,8 (in)	100 psi	1.200 psi	18,30 cu-in	40,0 lb/m	85 lb/m	37 lb
PM 45 - 25 MA □ ■	531 210	115 mm	25:1	180 kg (A)	446-855-50 (mm)	14 bar	350 bar	75 cc	6,0 kg/min	13,7 kg/m	23 kg
PM 45 - 40 MA □	531 410	115 mm	40:1	180 kg (A)	446-855-50 (mm)	14 bar	560 bar	50 cc	3,5 kg/min	10 kg/m	23 kg
PM 45 - 40 MB □	531 420	115 mm	40:1	50 kg (B)	446-650-50 (mm)	14 bar	560 bar	50 cc	3,5 kg/min	10 kg/m	18 kg
PM 45 - 70 MA □	531 710	115 mm	70:1	180 kg (A)	446-855-50 (mm)	7 bar	490 bar	29 cc	2,0 kg/min	5,4 kg/m	23 kg
PM 45 - 70 MB □	531 720	115 mm	70:1	50 kg (B)	446-650-50 (mm)	7 bar	490 bar	29 cc	2,0 kg/min	5,4 kg/m	18 kg
PM 45 - 70 MT □ ★	531 730	115 mm	70:1	Bulk tote (T)	446-490-50 (mm)	7 bar	490 bar	29 cc	2,0 kg/min	5,4 kg/m	18 kg
PM 60 - 80 MA □	532 810	150 mm	80:1	180 kg (A)	460-855-50 (mm)	7 bar	560 bar	50 cc	2,7 kg/min	6 kg/m	24 kg
PM 60 - 80 MB □	532 820	150 mm	80:1	50 kg (B)	460-650-50 (mm)	7 bar	560 bar	50 cc	2,7 kg/min	6 kg/m	20 kg
PM 60 - 12 MT □ ▲ ★	532 130	150 mm	12:1	Bulk tote (T)	460-226-70 (mm)	7 bar	84 bar	300 cc	18 kg/min	39 kg/m	17 kg

All Grease Pumps include a set of two handles fitted to the air motor base for easy pump handling.

\* Indicated Flow rates at 7 bar - 100 psi air inlet pressures. SAMOA recommends 40 cycles per minute or less for continuous-duty supply applications.

■ A Medium Pressure Lubricant Pump designed to deliver a range of heavy gear oils and light body greases up to NLGI 1 at any temperature range.

▲ Medium Pressure Transfer Pump designed to deliver a range of greases up to NLGI 3 from Bulk totes to small containers.

★ These Stubby Pumps include the male portion of a 3-inch camlock connection (length: 80 mm - 3.15") for easy installation in Bulk totes.

□ "M" Series Pumps ports are BSPP European style parallel threads at both air inlet and fluid outlet.